

FRIDAY 12TH APRIL 2019 LYON

1 BLACK DONALD J32 · 2/4L

Derek Haynes: Carnforth Collection of SC Dances 2 · Crib: E-cribs · Diagram: Keith Rose's Diagrams

- 1- 1c+2c advance {2}, give RH to P and W dance R about under his arm, and back to places as M retire (= Allemande right) ; RHA
- 9- 1c+2c Allemande left ; LHA
- 17- 1M followed by 1W cast | cross up between 2c ; cast off round 2W, cross to own side (2c up) (2,1)
- 25- 2c+1c R&L.

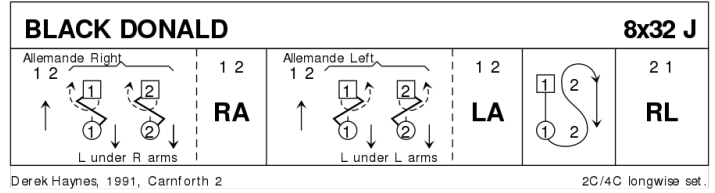

2 THE REEL OF THE ROYAL SCOTS R32 · 3/4L

Roy Goldring: The Leaflet Dances with Music · Crib: E-cribs · Diagram: Keith Rose's Diagrams

- 1- 1W+2W (1M+2M) turn LH (RH) ½, finishing 1c BtoB in 2pl | All set as in DTr ; 1W+3W (1M+3M) turn RH (LH) ½ | 2c+3c+1c set as in DTr
- 9- 1c followed by 3c dance up between 2c, cast off ; dance NHJ down through 3pl, cast up to face 1cnrs, 3c looping into 3pl
- 17- 1c turn 1cnrs RH, pass Rsh (cnrs dance for {4}) ; turn 2cnrs RH (same), and cross Rsh to (2,1,3)
- 25- All circle6 and back

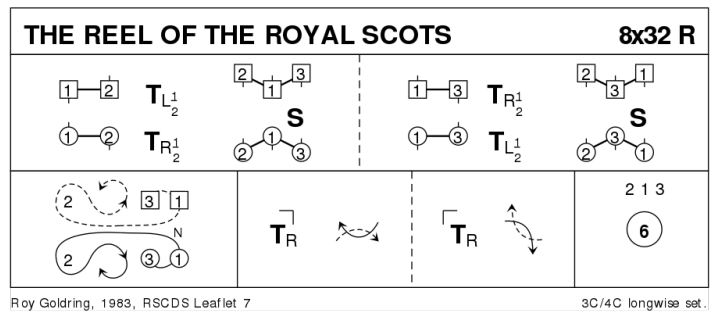

3 CULLA BAY S32 · 4S

Ann Dix: RSCDS XLI 2 · Crib: E-cribs · Diagram: Keith Rose's Diagrams

- 1- 1c+3c turn RH ½ with person opposite, face that person | twirl R and into opposite place ; 2c+4c repeat this and face in **while**{4} 1c+3c (W leading) chase ¼ clw | curve into centre and swivel R to face out (1c facing 4pl and 3c facing 2pl)
- 9- Parallel Reels4 across
- 17- 2c+1c & 3c+4c circle4 L ; face other couple and set | ½ RHA, flowing into
- 25- 2c+4c LHA in the middle ; dance out passing same sex standing dancer on the side Rsh, and chase R (M leading) to 1pl/3pl (to 2,3,4,1).

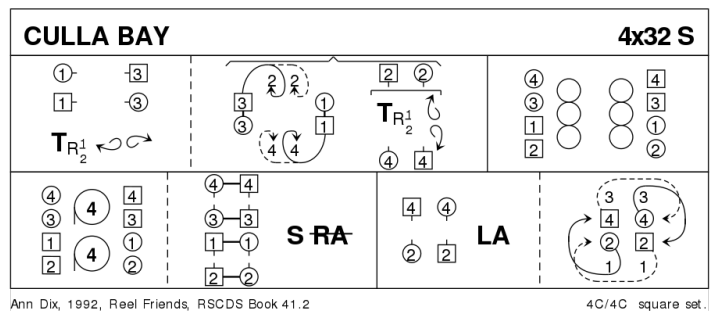

4 THE CHEQUERED COURT J32 · 3/4L

Duncan Brown: RSCDS XLII 3 · Crib: E-cribs · Diagram: Keith Rose's Diagrams

- 1- 1c cross RH | cast off (2c up) ; ½ Fig8 across to the R (1M up, 1W down) to face 1cnr
- 9- 1c+1cnrs pass and turn, at end 1c swivels R to be BtoB facing 4cnr ; 1c+4cnrs pass and turn, 1c swivels R to finish BtoB facing own side for DTr, 1c finish between end couple facing own side
- 17- DTr, 1c finish between end couple facing own side
- 25- Reels3{6} across (Rsh to 4cnr) | 1c cross RH (2,1,3)

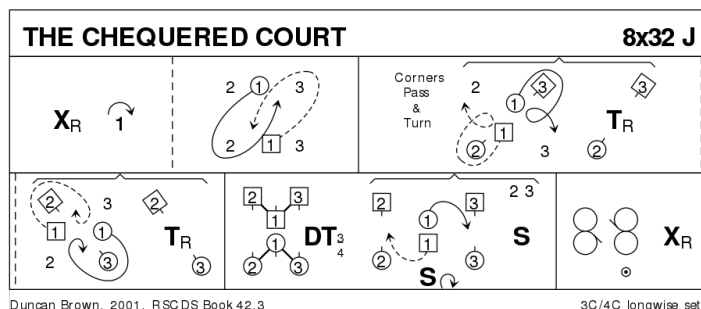

5 SUMMER WOONG R32 · 3/4L

Alan Macpherson: RSCDS XXXVIII 6 · Crib: E-cribs · Diagram: Keith Rose's Diagrams

- 1- 1c+2c circle4 to the left ; 1c+2c chase clw ½-round to finish on opposite sides, 2c facing 1c (2x,1x,3)
- 9- Rsh Reels3 on sides
- 17- 1c, followed by 2c lead down the middle {3}, (2c split for) 1c+2c lead up {3} | and cross to own side RHJ, the W passing below the M and under the joined arms, into
- 25- 1c+2c Poussette (2,1,3)

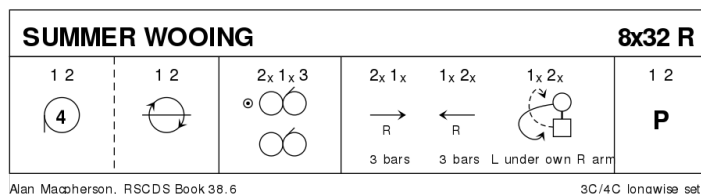

6 THE WISHING WELL S32 · 2/4L

Minnie Bänninger: RSCDS XLIV 6 · Crib: E-cribs · Diagram: Keith Rose's Diagrams

- 1- 1W+2M turn RH ¾ | turn P LH once, into diagonal line facing clw (1M+2W swivel L) ; Line rotates ¼ clw | 1M+2W (outers) dance on one place on sideline **while**{2} 1W+2M (inners) turn ½ RH to (2x,1x)
- 9- All C turn ½ RH and twirl to (2,1) ; Circle4 L
- 17- 1c set | turn BH and face up ; dance up | cast to 2pl
- 25- 2c+1c Poussette

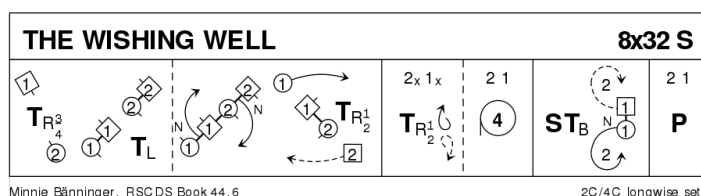

7 THE 51ST TRAVELLERS J32 · 3/4L

Sandra Turton: RSCDS XLIV 9 · Crib: E-cribs · Diagram: Keith Rose's Diagrams

- 1- 1c cross down RH behind 3c (2c up) and dance up to 2plx ; Mirror ½ Reels3 on the sides (1c out and up) (to 3,1x,2)
- 9- G-Chain (3c cross to begin)
- 17- S&Link3 ; 1c turn RH 1¾ to face 1cnr pos. **while**{4} 3c+2c chase ½ clw
- 25- 1c+1cnrs diag. ½Reel4 (1c pass Rsh) ; ½Reel4 with 2cnrs (pass Rsh to 2,1,3)

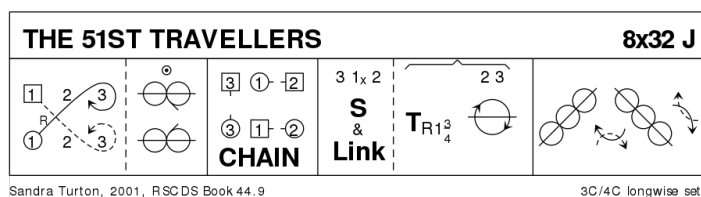

8 PROGRAMME ITEM – Interval

9 C'EST L'AMOUR J32 · 3/4L

RSCDS: RSCDS XXXIV 1 · Crib: E-cribs · Diagram: Keith Rose's Diagrams

- 1– 1W casts off one (2W up) | set to 2M ; repeat with 3M (3W up)
- 9– 1W (1M) cast up (down) to 2pl (3W & 2M step down/up), 1c set ; 1W (1M) casts up (down) to midline in 1pl (3pl) facing P | 1c set (2c & 3c step towards each other on sidelines)
- 17– 1W+2c & 1M+3c circle3 & back, 2c & 3c finish BtoB facing ends, NHJ
- 25– All set | 2c+3c dance to ends making arches as 1W & 1M dance under arches to 2pl ; 2c+1c+3c turn RH (2,1,3)

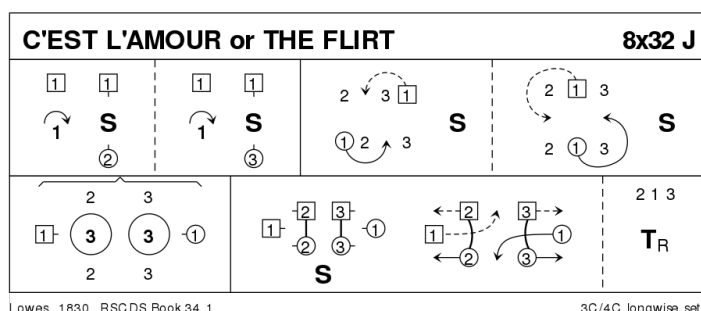

10 SO FAR YET SO CLOSE S32 · 3/4L

Claire Cunin · Crib: E-cribs · Diagram: Keith Rose's Diagrams

- 1-- 1c dance down | cast up round 2c to 1pl ; lead down, cross and cast up round 3c to 2plx (2c up) (2,1x,3)
- 9-- 1c turn BH ¾, face P and cast away into facing lines3 across (2c+1M & 1W+3c) ; 3C S&Link (2x,1x,3x)
- 17-- Reels3 across, 1c RSh to 4cnrs[pos] (2x,1x,3x)
- 25-- 1c set ; Petronella turn **while{4}** 2c & 3c Turn BH Halfway and Cast away ; 1c turn BH ¾, face P and cast away to 2pl (2,1,3)

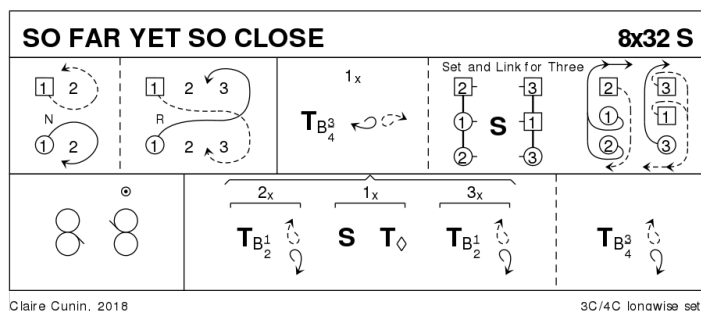

11 RAMADAN-CE R32 · 3/4L

John Drewry: The Turkish Set · Crib: E-cribs · Diagram: Keith Rose's Diagrams

- 1– 1c+2c+3c Inveran Reels (1,2,3)
- 9– 1c cross RH | cast (2c up) ; Turn RH to face 1cnr
- 17– 1c+1cnrs pass Rsh | cnrs turn RH ½ and cast away as 1c meet and pass Rsh to face 2cnrs ; repeat with 2cnrs (3x,1x,2x)
- 25– ½ Reels3 across, 1c Lsh to 3cnr ; ½ Reels3 on the sides, 1c Rsh to 4cnr (2,1,3)

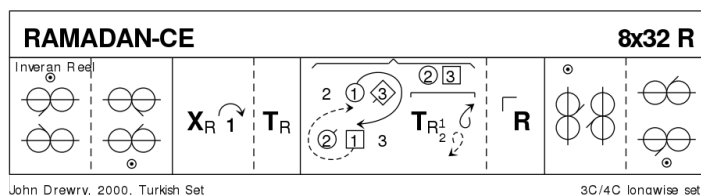

12 THE FESTIVAL MAN J32 · 3/4L

Sheila Trafford: RSCDS XLVIII 10 · Crib: E-cribs · Diagram: Keith Rose's Diagrams

- 1-- 1c set | cross down RH (2c up) ; set to P | turn LH $\frac{3}{4}$ to between ends facing 1cnr
- 9-- $\frac{1}{2}$ Reels3 across, 1c Lsh to 1cnr, 1c pass Lsh into ; $\frac{1}{2}$ Reels3 across, Lsh to 3cnr, 1c finish side by side in the middle facing 4cnr
- 17-- All M & All W RHA on the sides ; 1c cast Rsh round 4cnr to 2pl while{4} 2W+3W & 2M+3M set and change places RH to (3,1,2)
- 25-- Set&Rotate for three [All Set | all cast clw to lines across ; all cpls change place RH | all chase clw to (2,1,3)]

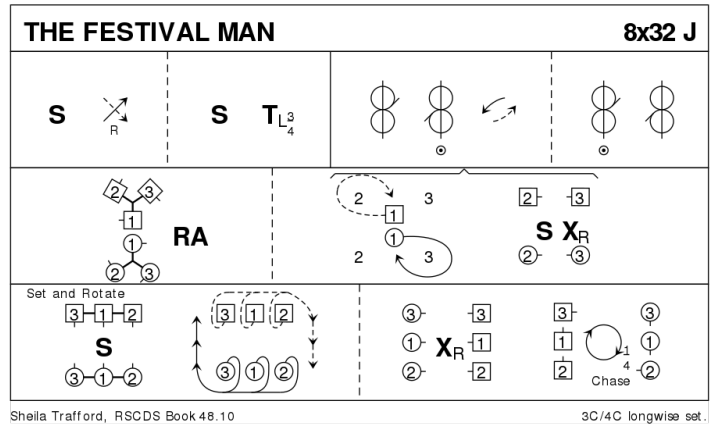

13 THE FLOWER OF GLASGOW S32 · 3/3L

Ruth Taylor (CAN): RSCDS XLVI 9 · Crib: E-cribs · Diagram: Keith Rose's Diagrams

- 1-- 1W, 1M following, cast off 2, cross below 3c ; 1W cast up and 1M dance up the middle and 2c dance up (to 2,1x,3) | All set adv into promhold, 1c facing down, 2c & 3c up
- 9-- Circulating Allemande: all dance as in a normal 3c allemande, only 1c starts down, finish (3,1x,2)
- 17-- 1c $\frac{1}{2}$ Fig8 L (W up M down) ; all turn P BH (3,1,2)
- 25-- 1c+2c Poussette (3,1,2)

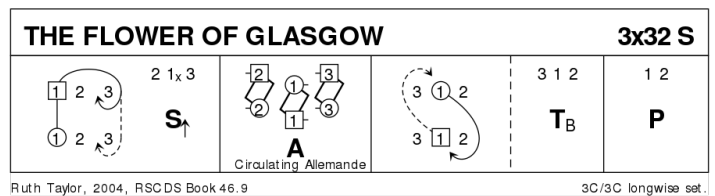

14 IAN POWRIE'S FAREWELL TO AUCHTERARDER

J128 · 4S

Bill Hamilton: 90 - Twelve anniversary dances celebrating ninety years of RSCDS Edinburgh Branch 13 · Crib: E-cribs · Diagram: Keith Rose's Diagrams

- 1-- Circle8 L and back
- 9-- All W pass in front of P, dance behind next M ; RHA in the centre
- 17-- All W cross in front of opposite M, dance behind next M ; RHA, joining P for
- 25-- All Promenade once round clw (but see note)
- 33-- 1c+3c (W following M) dance on 1 place clw and in (M round M, W round W) to face next couple ; set to and turn that person RH
- 41-- Reels4 across
- 49-- Fig8, 1c round 2c, 3c round 4c
- 57-- 1c+3c LHA ; 1c/3c dance out Lsh round 2c/4c (M round M, W round W) and cclw to places
- 65--96 2c+4c repeat bars 33-64
- 97-- All Promenade once round cclw
- 105-120 The Men repeat [9-24] cclw with LHA in the centre
- 121-- Circle8 RIGHT and back (see note)

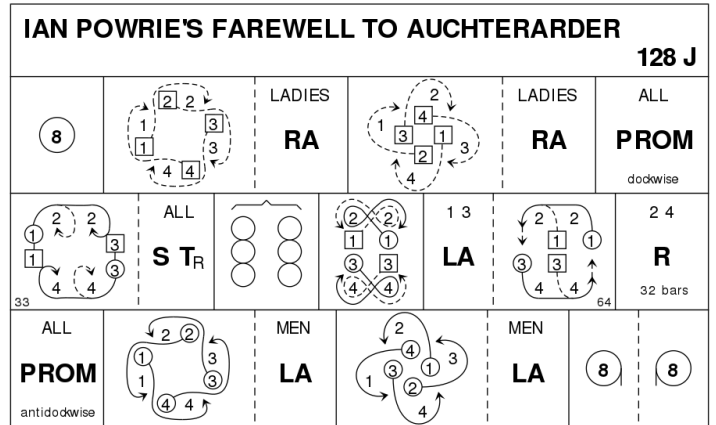

Bill Hamilton, Ian Powrie's Farewell to Auchterarder, Edinburgh 90th 4C/4C square set.

Note: This crib follows the current way of dancing. In the original instructions, the promenade [25-32] is cclw. Bill Hamilton said in 'hindsight' this promenade should be clw, but preferred not to change the official instructions. Bill disapproved of another variant, where the circle [121-128] is continued to the R only.

15 THE MONTGOMERIES' RANT

R32 · 3/4L

Castle Menzies (18C): RSCDS X 1 · Crib: E-cribs · Diagram: Keith Rose's Diagrams

- 1- 1c cross RH | cast off (2c up) ; cross LH | cast L (W up, M down)
- 9- 2c+1W & 1M+3c Rsh Reels3 across
- 17- 1c NHJ set to 2W (swivel 1/2 inwards), set to 3M (veer L together), set to 3W (swivel 1/2 inwards), set to 2M (and face own 2cnr)
- 25- Reels3{6} on the sides, Rsh to 2cnr | 1c cross RH to 2pl

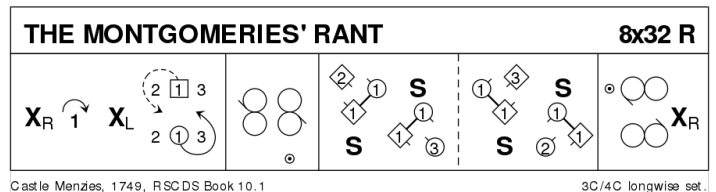

Castle Menzies, 1749, RSCDS Book 10.1 3C/4C longwise set.