

November 2017 Friday

1 BERWICK JOHNNIE J32 · 3/4L

RSCDS Graded 14 · Crib: Eric's E-cribs · Diagram: Keith Rose's Diagrams

- 1- 1c+2c set | ½ RHA ; set | ½ LHA
- 9- 1c down the middle and up, into
- 17- 1c+2c Allemande, 1c finishing facing 1cnr
- 25- Turn CPCP

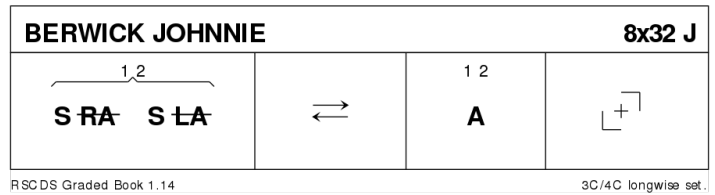

2 KARIN'S STRATHSPEY S32 · 3/4L

Derek Haynes: A Third Book of Graded Scottish Country Dances · Crib: Eric's E-cribs · Diagram: Keith Rose's Diagrams

- 1- 1c+2c the Knot
- 9- 1c set advancing towards 1cnrs, turn corner BH ; open into circle4 L, ending with 1cnrs in places and 1W+2c & 1M+3c forming lines across
- 17- 1c repeat with 2cnrs, to finish between corners
- 25- Lsh Reels3{6} on opposite sides with cnrs | 1c cross to own side

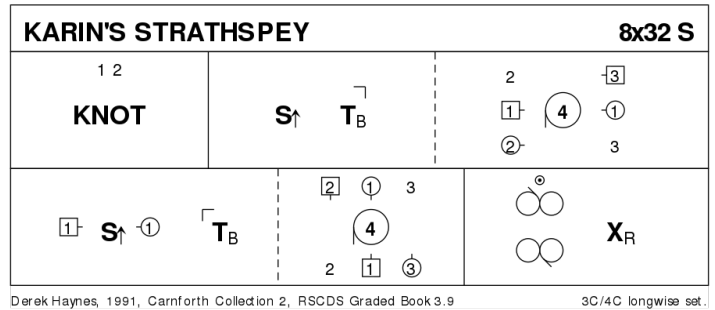

3 DA RAIN DANCIN' R32 · 3/4L

Ron Wallace: Whiteadder Collection · Crib: Eric's E-cribs · Diagram: Keith Rose's Diagrams

- 1- 1c dance down 2 places and cast up to 2pl (2c up) ; 2c+1c+3c set and cross RH (2x,1x,3x)
- 9- 1c dance up and cast off one ; 2c+1c+3c set | 2c+3c cross LH while {2} 1c turn LH to face 1cnr:
- 17- 1c set R to 1cnr {1} and L to P {1} | turn ¾ RH ; set R to 2cnr and L up/down to P | turn ¾ RH to 2pl
- 25- 2c+1c+3c circle6 and back. (2,1,3)

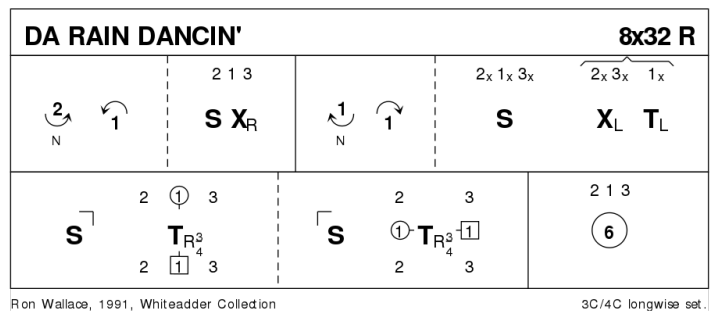

4 A CAPITAL JIG J32 · 3/4L

Tine E MacKay: Magazine Dances 2005-2009 · Crib: Eric's E-cribs · Diagram: Keith Rose's Diagrams

- 1- 1c+2c Set&Rotate, finish 1c facing 2c (2,1,3)
- 9- Rsh Reels3 on the sides
- 17- 1c set | turn $\frac{3}{4}$ RH ; 2c+1W & 1M+3c LHA (to 2,1x,3)
- 25- 1c set | turn $\frac{3}{4}$ RH ; 2c+1M & 1W+3c LHA (2,1,3)

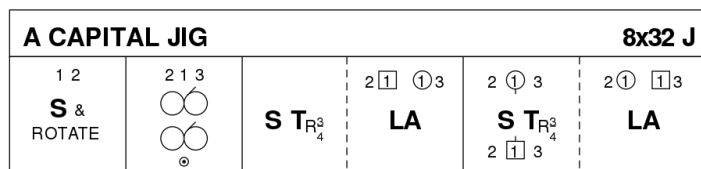

Tine MacKay, RSCDS 5/2009

3C/4C longwise set.

5 S-LOCOMOTION S32 · 4/4L

Ken Jones: RSCDS XLI 8 · Crib: Eric's E-cribs · Diagram: Keith Rose's Diagrams

- 1- 1W+2W & 3M+4M cross Lsh past P | cast two L to each other's places ; all M (top) and W (bottom) LHA
- 9- 1M+2M & 3W+4W cross Rsh to person opposite | cast two R ; 3c+4c (top) & 1c+2c (bottom) RHA (to 3x,4x,1x,2x)
- 17- $\frac{1}{2}$ Reels4 on the sides ; 2c waits in 1plx **while{4}** the others continue in $\frac{1}{2}$ Reel3 (to 2x,3x,4x,1x)
- 25- All Set, cross RH, 2c+3c & 4c+1c circle4 left

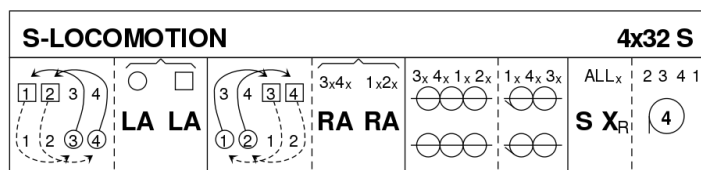

Ken Jones, 1998, RSCDS Book 41.8

4C/4C longwise set.

6 THE KISSING BRIDGE R32 · 3/4L

Romaine Butterfield: RSCDS XLVII 9 · Crib: Eric's E-cribs · Diagram: Keith Rose's Diagrams

- 1- 1c cast behind own lines and cast back
- 9- 1c cross down into Mirror Reels3 on opposite sides (1x,2,3)
- 17- 1c lead down, cross (M below W, who passes under M's arm) ; and up, 2c steps in for
- 25- 1c+2c Poussette

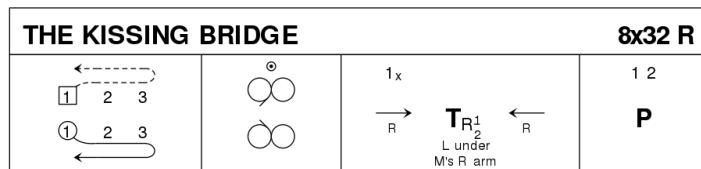

Romaine Butterfield, RSCDS Book 47.9

3C/4C longwise set.

7 PROGRAMME ITEM – INTERVAL

8 FOLLOW ME HOME J32 · 3/4L

Ellie Briscoe: RSCDS XXXVIII 3 · Crib: Eric's E-cribs · Diagram: Keith Rose's Diagrams

- 1-- 1c set | cross RH ; cast off (2c up) | turn $\frac{3}{4}$ LH
- 9-- BiL with 1cnrs | $\frac{1}{2}$ turn 1cnrs RH ; 1c followed by 1cnrs chase clw round 4cnrs to leave 1cnrs in exchanged places, and join LH to 2cnr, RH to P
- 17-- BiL with 2cnrs | $\frac{1}{2}$ turn 2cnrs LH ; 1c followed by 2cnrs chase cclw, 1c crossing Lsh to 2plx facing out (3x,1x,2x)
- 25-- $\frac{1}{2}$ Lsh Reels3 on the sidelines ; All set and cross (2,1,3)

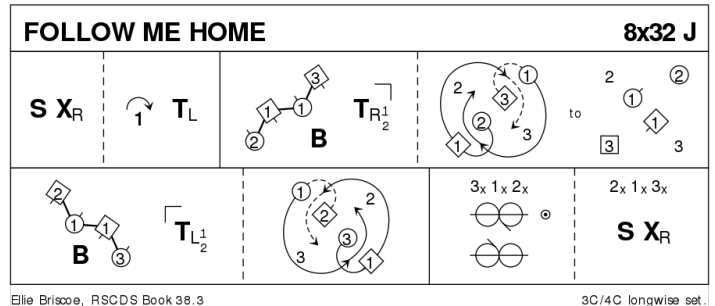

9 MIDSUMMER COMMON S32 · 3/4L

Tom & Lindsey Ibbotson: RSCDS XLIX 3 · Crib: SCDDDB Contributed Cribs & Diagrams · Diagram: Keith Rose's Diagrams

- 1-- 1c set | $\frac{1}{2}$ turn RH ; lead down, cross below 3c (2c up on [5-6] and cast to 2pl (2,1,3)
- 9-- 1c set adv to into BtoB facing 1cr while 1cr set | turn 1cnr BH into lines across ; 1c set adv to into BtoB facing 2cr while 2cr set | turn 2cnr BH
- 17-- 1W+3c & 1M+2c circle3, at end 1c swivels R to face P ; 1c set | 1c Petronella turn (to 2,1,3)
- 25-- 1c+2c poussette

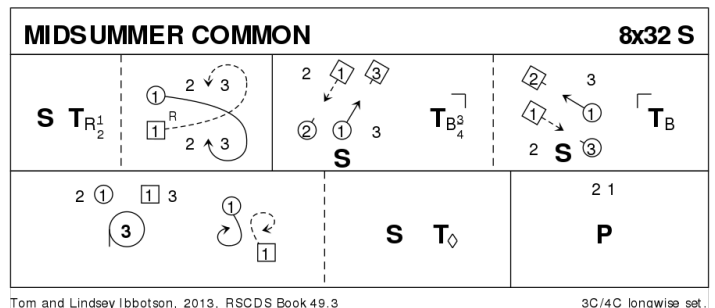

10 THE FALLS OF ROGIE R32 · 3/4L

Jean Attwood: Alexander Dances Book 1 · Crib: Eric's E-cribs · Diagram: Keith Rose's Diagrams

- 1-- 1c cross RH | cast (2c up) ; cross RH | cast R (M up, W down)
- 9-- $\frac{1}{2}$ Reels3 across (Lsh to 2cnr) ; set in lines across | all cross up/down RH
- 17-- Corners chase once clw **while{8}** 1c chase half way clw and turn RH $\frac{1}{4}$ to face 1cnr positions
- 25-- $\frac{1}{2}$ diag. Reel4 with 1cnrs, 1c pass Rsh ; $\frac{1}{2}$ diag. Reel4 with 2cnrs, 1c passing Rsh to 2pl.

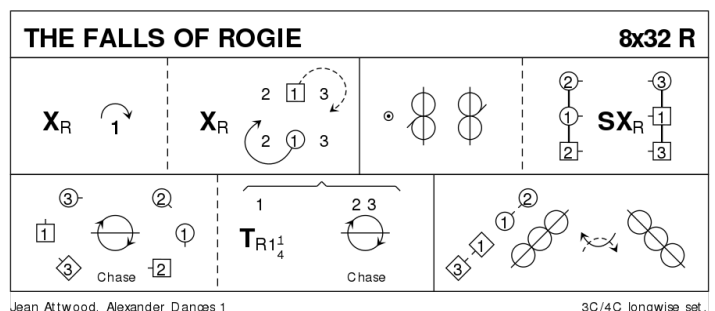

11 THE WEATHERCOCK J32 · 4/4L

Veronica Hughes: *A Second Book of Graded Scottish Country Dances* · Crib: *Eric's E-cribs* · Diagram: *Keith Rose's Diagrams*

- 1- Parallel Reels4 on the sides
- 9- 1c+3c set advancing to midline and join RH with P, LH in middle | BiL (2c+4c up) ; 1c+2c & 3c+4c RHA
- 17- 1W+3M turn LH $\frac{3}{4}$ while } 1M+3W dance round clw $\frac{1}{4}$ to meet P in line across | BiL ; repeat
- 25- 3c+2c & 1c+4c RHA ; 1c+3c turn person ahead («corner») RH to finish (2,3,4,1) (M turn once and a bit, W turn $1\frac{1}{2}$ and a bit)

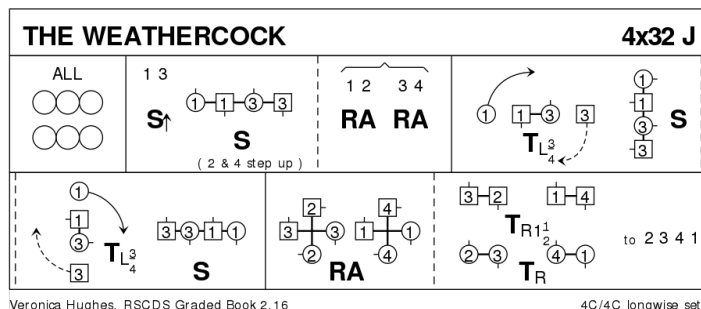

note: the set tends to move upwards; ease down gently in the turns to end in the right positions

12 SUGAR CANDIE S32 · 3/4L

RSCDS XXVI 9 · Crib: *Eric's E-cribs* · Diagram: *Keith Rose's Diagrams*

- 1- 1c set | cast off (2c up), pass Lsh and cast R round 1cnr, to finish BtoB in the centre, M facing down, W up
- 9- 1W+2c & 1M+3c circle3, at end 1c swivels R to face P ; 1c set, turn $\frac{3}{4}$ BH to face 1cnrs (open out with 1M using RH to assist P)
- 17- Turn CPCP
- 25- Reels3{6} with corners, Lsh to 1cnr, 1c cross RH to (2,1,3)

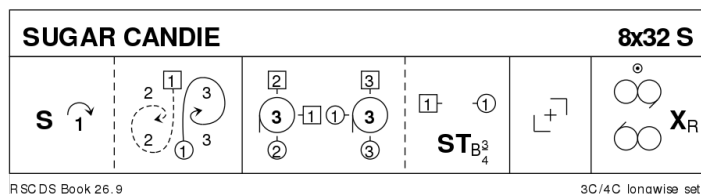

13 THE REEL OF THE 51ST DIVISION R32 · 3/4L

James Edward McCartney Atkinson: *RSCDS XIII 10* · Crib: *Eric's E-cribs* · Diagram: *Keith Rose's Diagrams*

- 1- 1c set | cast off two places (2c up) and lead up to 1cnrs
- 9- 1c set to 1cnr | turn 1cnr RH and join LH in the middle ; BiL | turn $1\frac{1}{4}$ LH to 2cnrs
- 17- Repeat with 2cnrs | cross to (2,1,3)
- 25- 2c+1c+3c circle6 and back.

